

WALL & CEILING MOUNT LUMINAIRES

Jupiter Bulkhead

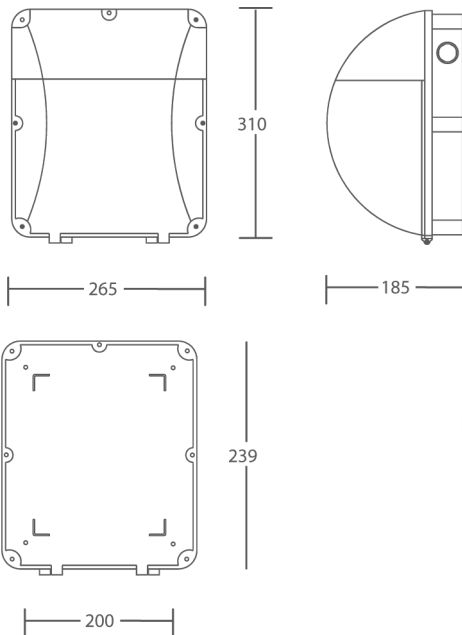

Approximate Dimensions:



General Data:

Construction:

Manufactured From die cast aluminium. Internal components accessible through stainless steel screws with a hinged clear injection moulded polycarbonate with internal prisms for a more uniform lighting.

Reflector High purity anodised aluminium for maximum light efficiency and light output.

IP Rating IP65

Typical Applications:

External Applications Parking areas
Shopping center lighting
Park and garden lighting
Exterior wall applications



WALL & CEILING MOUNT LUMINAIRES

Jupiter Bulkhead



Product Information:

Product Type	LampWatt's	Lumens (Lm)	H (mm)	L (mm)
HID-Metal Halide	70W	7200	310 mm	265 mm
HID-High Pressure Sodium	70W	6300	310 mm	265 mm
HID-Mercury Vapour	80W	4000	310 mm	265 mm
HID-Mercury Vapour	125W	6800	310 mm	265 mm
CFL	2 x 18W	2400	310 mm	265 mm
CFL	2 x 26W	3600	310 mm	265 mm
LED	20W	1350	310 mm	265 mm
LED	40W	4000	310 mm	265 mm

Complete your Project:

Please select the items you require and we will be in touch

Cables and Wires:

Indoor
Outdoor
General
Other
Let an ACTOM
Specialist Contact you

Lighting:

Indoor
Outdoor
General
Other
Let an ACTOM
Specialist Contact you

Transformers (Distribution):

Indoor
Outdoor
General
Other
Let an ACTOM
Specialist Contact you

Accessories:

Indoor
Outdoor
General
Other
Let an ACTOM
Specialist Contact you

Specific Information:

Address: 4 Branch Road, Germiston 1401, P.O. Box 678, Germiston 1400

For more Information on this Product Please Send us the Following

Product Information:

Product Name:

Quantity:

Project Name:

Date the Product is required:

Your Contact Information:

Name and Surname:

Company:

Email:

Phone Number:

Province:

Thank You

For having a Look at this Product

Please send this PDF back to us with all your Information

Scan the QR Code to visit our Website:

